

HLSC

HI-FAB Universal Lip Seal Cartridge

Features:

- Cartridge Design for easy installation
- Designed to work in extremely arduous conditions.
- Can work efficiently on rotating shafts with axial floats.

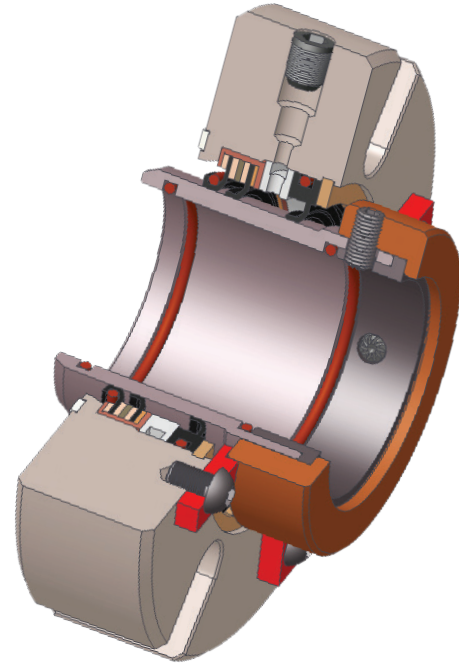

Media

Adhesive, AFFF, Asphalt, Chocolate, Emulsions, Fats, Fructose, Fuels, Glue, Ink, Latex, Molasses, Oil, Paints, Paper Coatings, Polymer Resins, Sealants, Soaps, Starch, Syrups, Tallow, Tar, Varnish, Wax

Applications

- Positive displacement pumps made by Viking, Moyno, Blackmer, Roper, Tuthill and many others
- Centrifugal pumps made by Durco, Goulds and many others
- Screw Conveyors
- Rotary Valves

LIMITING PARAMETERS

PRESSURE UPTO 10 BAR	TEMPERATURE Up to 150°C	MAX SPEED Upto 3.5 m/s for Dry Running Upto 12.7 m/s with Lubrication	MAX RUN OUT 0.005" (0.13 mm) TIR
AXIAL MOTION +/- 0.125" (3.12mm)	VISCOSITY Upto 16,000 Centistokes	MAX VACUUM 700 mm of Hg	

MATERIALS

METAL PARTS SS316 (Other materials available)	O-RINGS Fluoroelastomer standard (Other materials optional)	SEALING ELEMENTS HIFLON®	SLEEVE Silicon, Hastelloy, Stainless Steel hard coated
--	--	------------------------------------	---

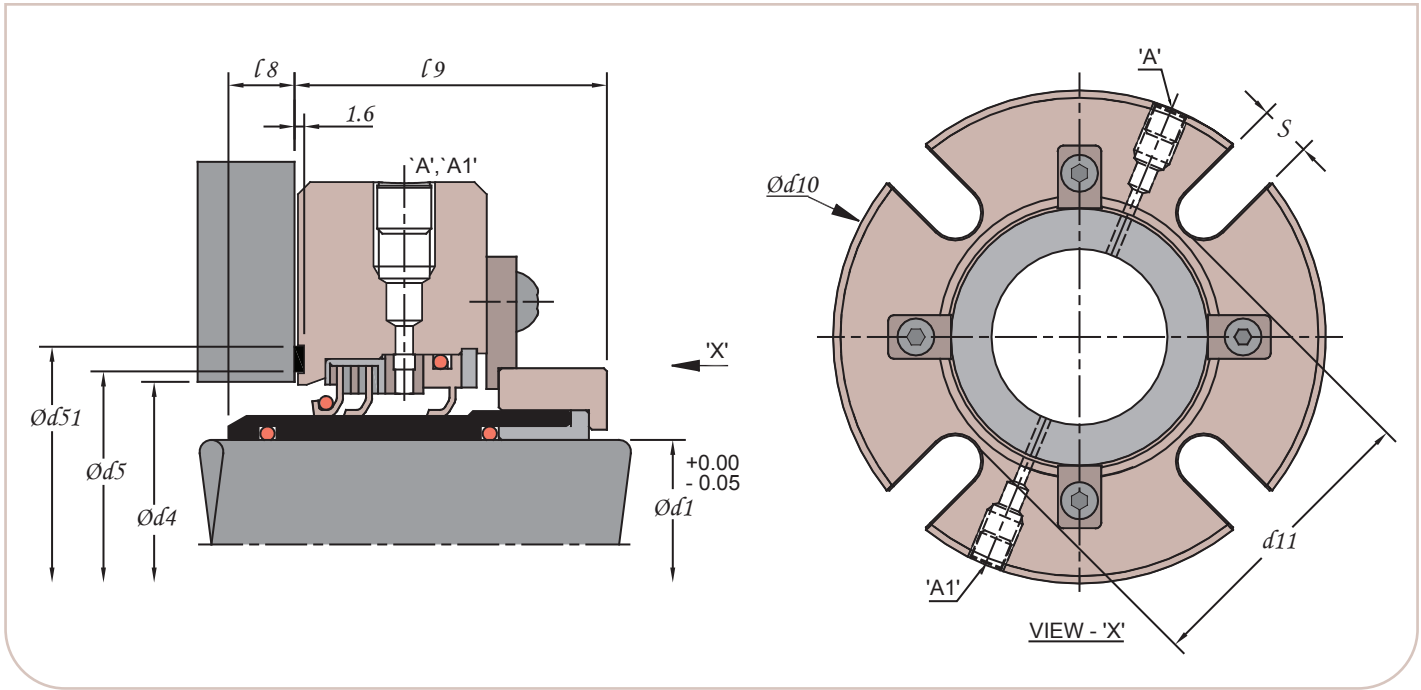

NORMAL BORE

SIZE CODE	d1	d4	d5	d51	d10	d11	l8	l9	SLOT WIDTH 's'
0254	25.40	41.27	45.00	53.50	101.60	57.00	11.00	52.00	14.00
0285	28.57	44.45	48.50	58.00	105.00	61.50	11.00	52.00	14.00
0317	31.75	50.80	51.75	60.00	108.00	63.50	11.00	52.00	14.00
0349	34.92	50.80	54.50	64.50	108.00	68.50	11.00	52.00	14.00
0381	38.10	57.15	60.15	69.50	114.30	71.50	11.00	52.00	14.00
0412	41.27	60.32	62.50	72.50	114.30	75.50	11.00	52.00	14.00
0444	44.45	63.50	65.50	76.00	127.00	77.80	11.00	52.00	14.00
0476	47.62	66.67	70.00	79.00	133.40	81.00	11.00	52.00	14.00
0508	50.80	69.85	72.00	83.00	139.70	86.00	11.00	55.60	14.00
0539	53.97	73.02	75.00	86.00	146.00	89.00	11.00	55.60	18.00
0571	57.15	76.20	79.00	89.00	165.10	92.00	11.00	55.60	18.00
0603	60.32	79.37	82.00	94.00	165.10	97.00	11.00	55.60	18.00
0635	63.50	85.72	88.00	98.00	165.10	101.00	11.00	69.10	18.00

Dimensions for higher sizes available on request.

Dimensions for Big Bore available on request.

Design Variations

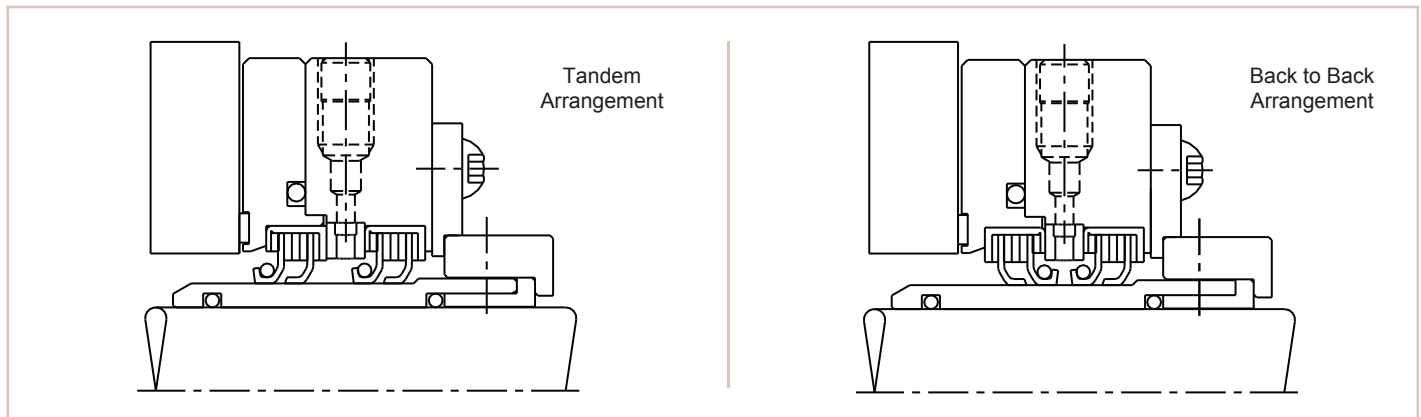

HI-FAB ENGINEERS PVT. LTD.

B-1103, WESTERN EDGE II, KANAKIA SPACES,
BORIVALI EAST, MUMBAI-400066, INDIA

Email: info@hi-fab.com, Website : www.hi-fab.com

Tel. No.: +91-22-40766555, Fax: +91-22-40766556